

# Atmospheric Flight

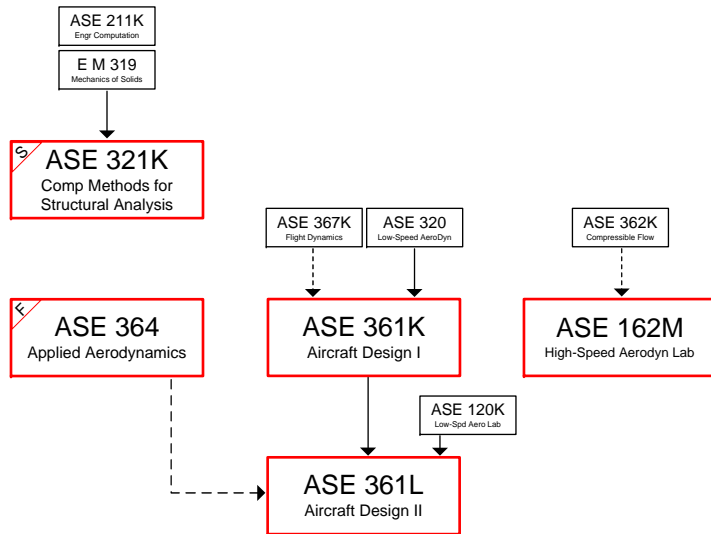

# Space Flight

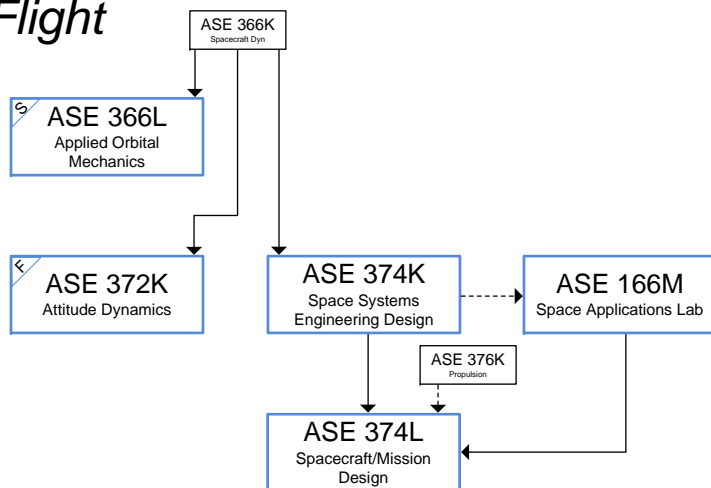

# Technical Area Options

## Pre-Approved Technical Area Electives:

- (F) ASE 339, Advanced Strength of Materials
- (F) ASE 346, Viscous Fluid Flow
- (S) ASE 347, Intro to Computational Fluid Dynamics
- (S) ASE 355, Aeroelasticity
- (S) ASE 357, Mechanics of Composite Materials
- (F) ASE 372N, Satellite-Based Navigation
- \*ASE 125N/225M/325L, Cooperative Engineering
- \*ASE 128, ASE Projects Laboratory
- \*ASE 1/2/379K, Undergraduate Research

\*Must add up to 3 hours of total credit to fulfill the technical area elective.

Tech Area Elective

F = Course Offered in **Fall Semester Only**

S = Course Offered in **Spring Semester Only**